

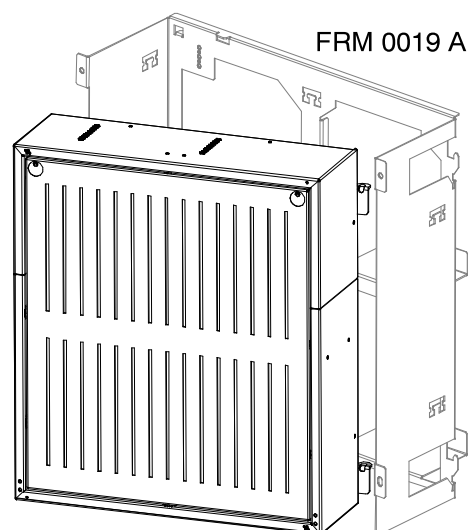

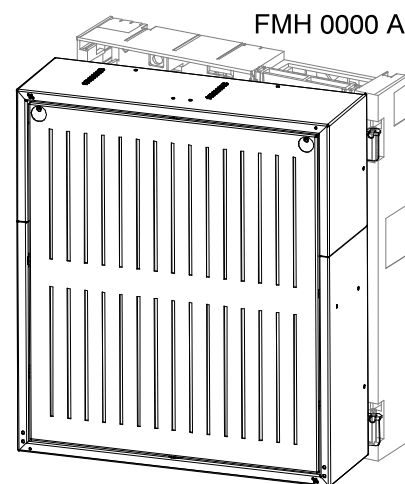

- AL** **Pershkrimi i pajisjes / Manual i instalimit**
Ushqyes i mesëm, instalimi i telajos
- BG** **Описание на продукта / Инструкция за монтаж**
Захранващ блок, среден, монтаж върху рамка
- CZ** **Popis produktu / Instalační manuál**
Napájecí zdroj (střední) k instalaci do rámu
- D** **Produktbeschreibung / Montageanleitung**
Netzteil mittelgroß, Rahmenmontage
- DK** **Produktbeskrivelse / Installationsmanual**
Strømforsyning mellemstørrelse, rammemontering
- E** **Descripción del Producto / Manual de Instalación**
Fuente de alimentación tamaño medio, instalación en bastidor
- EST** **Toote kirjeldus / Monteerimisjuhised**
Toiteallikas, keskmise, raampaigaldus
- F** **Description de produit / Manuel d'installation**
Alimentation électrique format moyen, installation sur cadre
- FIN** **Tuotekuvaus / Asennusohjeet**
Keskikokoisen yksikön virtalähde, kehysasennus
- GB** **Product description / Installation manual**
Power supply medium, frame installation
- GR** **Περιγραφή προϊόντος / Οδηγίες συναρμολόγησης**
Ηλεκτρική τροφοδοσία μεσαία, εγκατάσταση πλαισίου
- H** **Termékleírás / Telepítési kézikönyv**
Keretre szerelhető közepes tápegység
- HR** **Opis proizvoda / Priručnik za instaliranje**
Napajanje srednje, montaža na okvir
- I** **Descrizione prodotto / Manuale di installazione**
Alloggiamento medio per alimentazione, montaggio su telaio
- LT** **Gaminio aprašymas / Surinkimo instrukcija**
Maitinimo blokas, vidutinis, rėmo montavimas
- LV** **Izstrādājuma apraksts / Montāžas norādījumi**
Vidēja strāvas padeve, karkasa iekārta
- N** **Produktbeskrivelse / Monteringsinstruksjoner**
Mellomstor strømforsyning, rammeinstallering
- NL** **Productomschrijving / Installatiehandleiding**
Voeding middelgroot, framemontage
- P** **Descrição de Produto / Manual de Instalação**
Fonte de alimentação média, instalação em bastidor
- PL** **Opis produktu / Instrukcja instalacji**
Asilacz, średni, montaż w ramie
- RO** **Prospecte / Manual de Instalara**
Sursă de alimentare medie, montare pe cadru
- RUS** **Техническое описание / Инструкция по установке**
Источник питания, средний, для установки на раме
- S** **Produkt beskrivning / Installation manual**
Elförsörjning medium, raminstallation
- SCG** **Opis proizvoda / Instalacijski priručnik**
Srednje napajanje, postavljanje okvira
- SLO** **Opis izdelka / Priročnik za montažo**
Napajalni medij, namestitev okvirja
- TR** **Ürün tanımı / Kurulum kılavuzu**
Orta boy güç kaynak ünitesi, gövdeye montaj

PMF 0002 A
F.01U.511.306

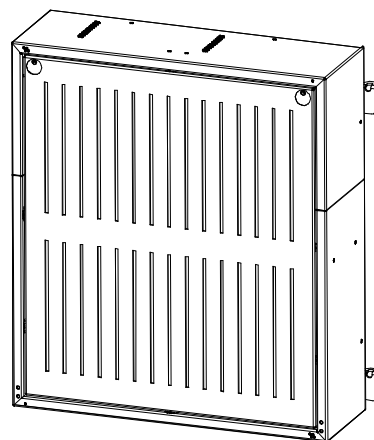
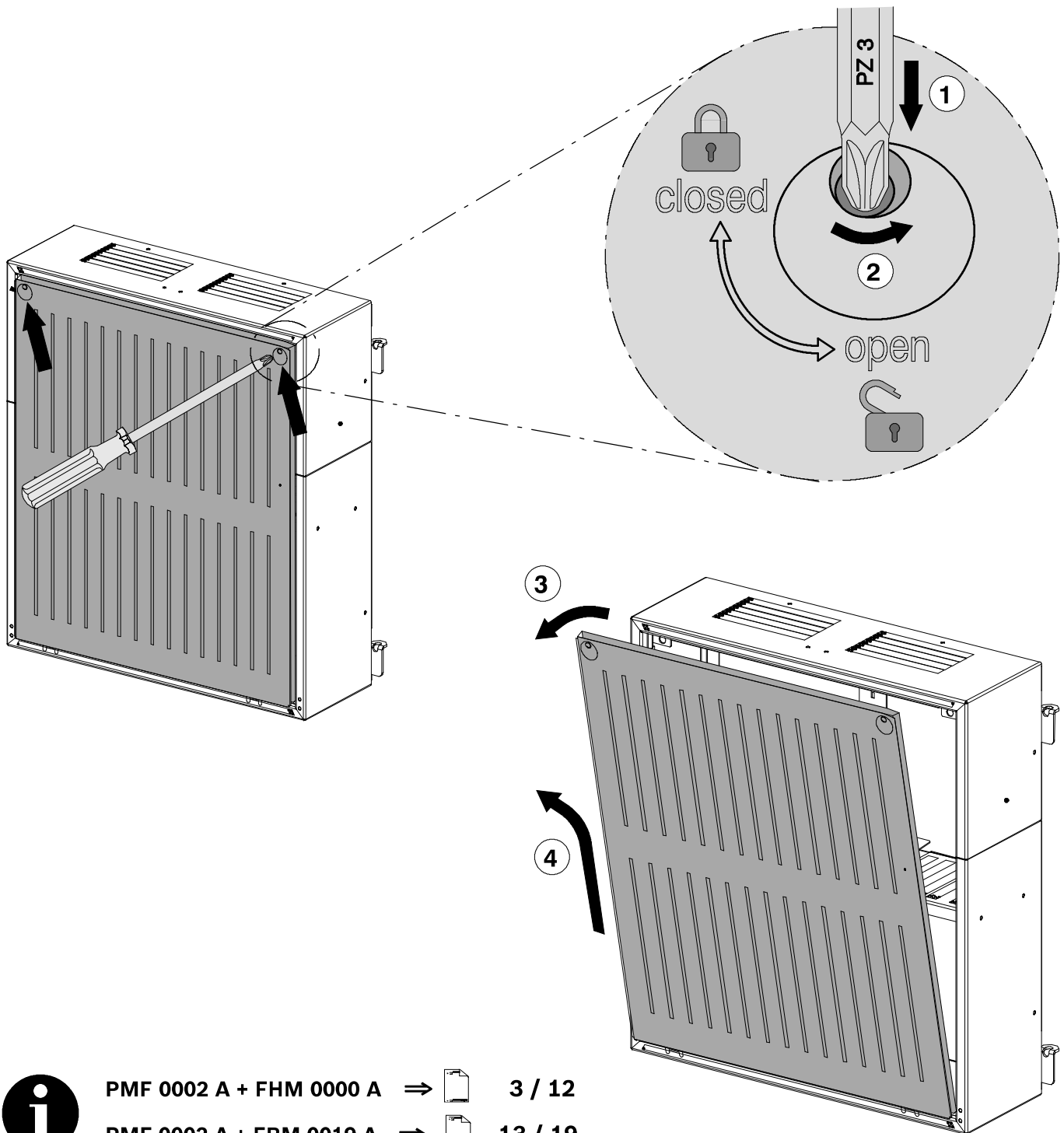
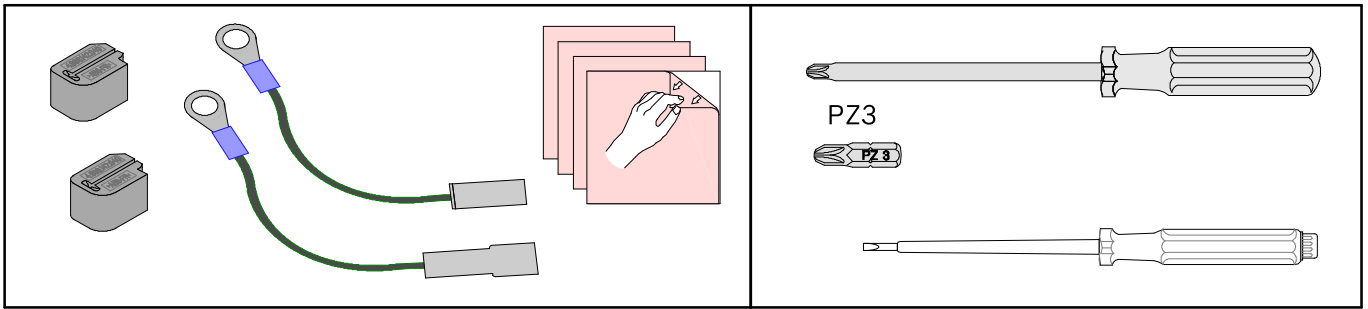



PMF 0002 A + FHM 0000 A ⇒  3 / 12

PMF 0002 A + FRM 0019 A ⇒  13 / 19

5

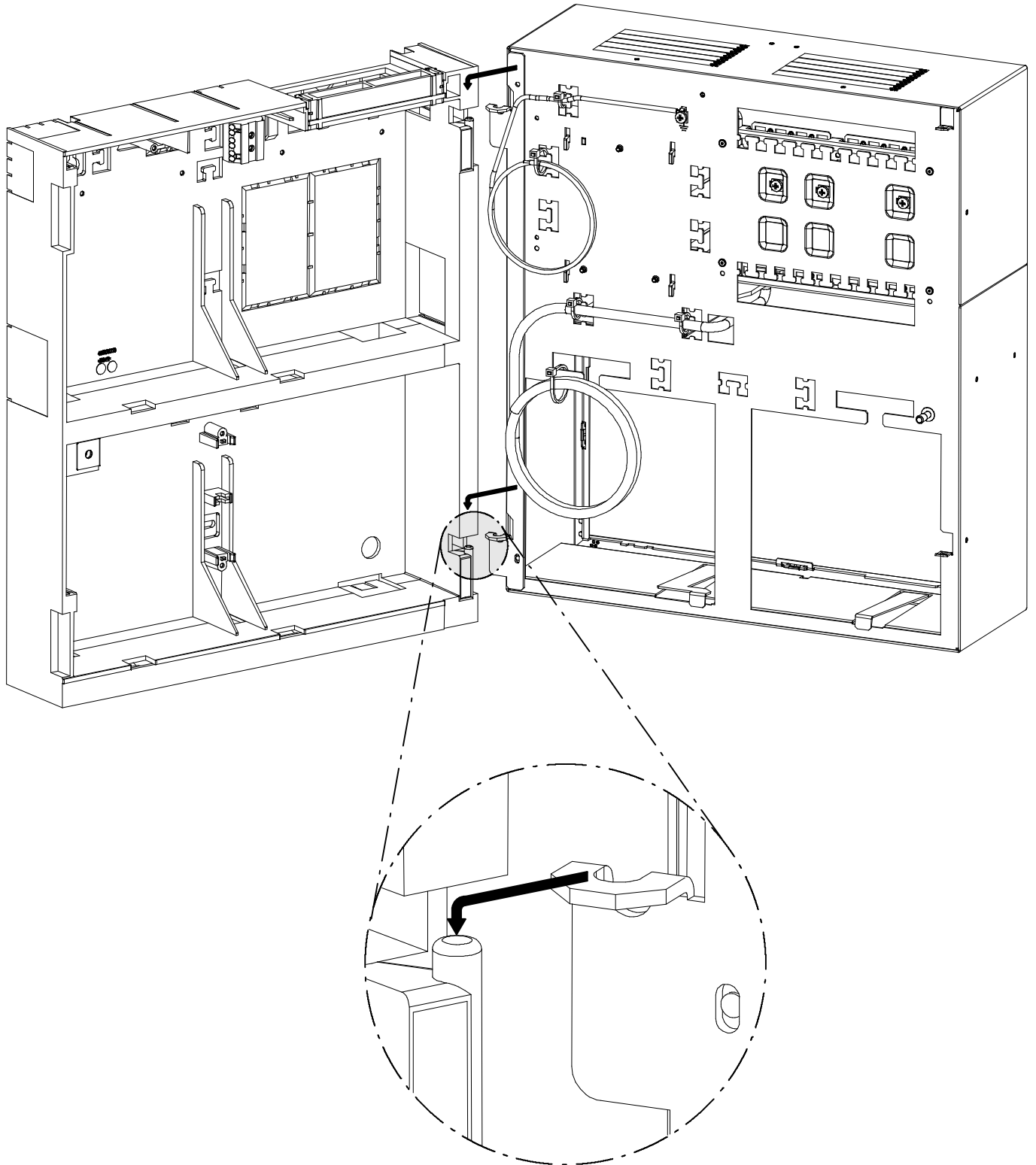



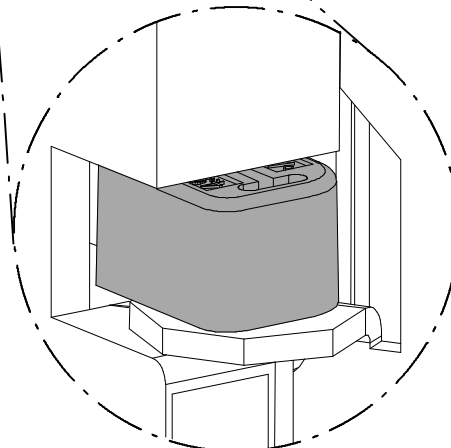
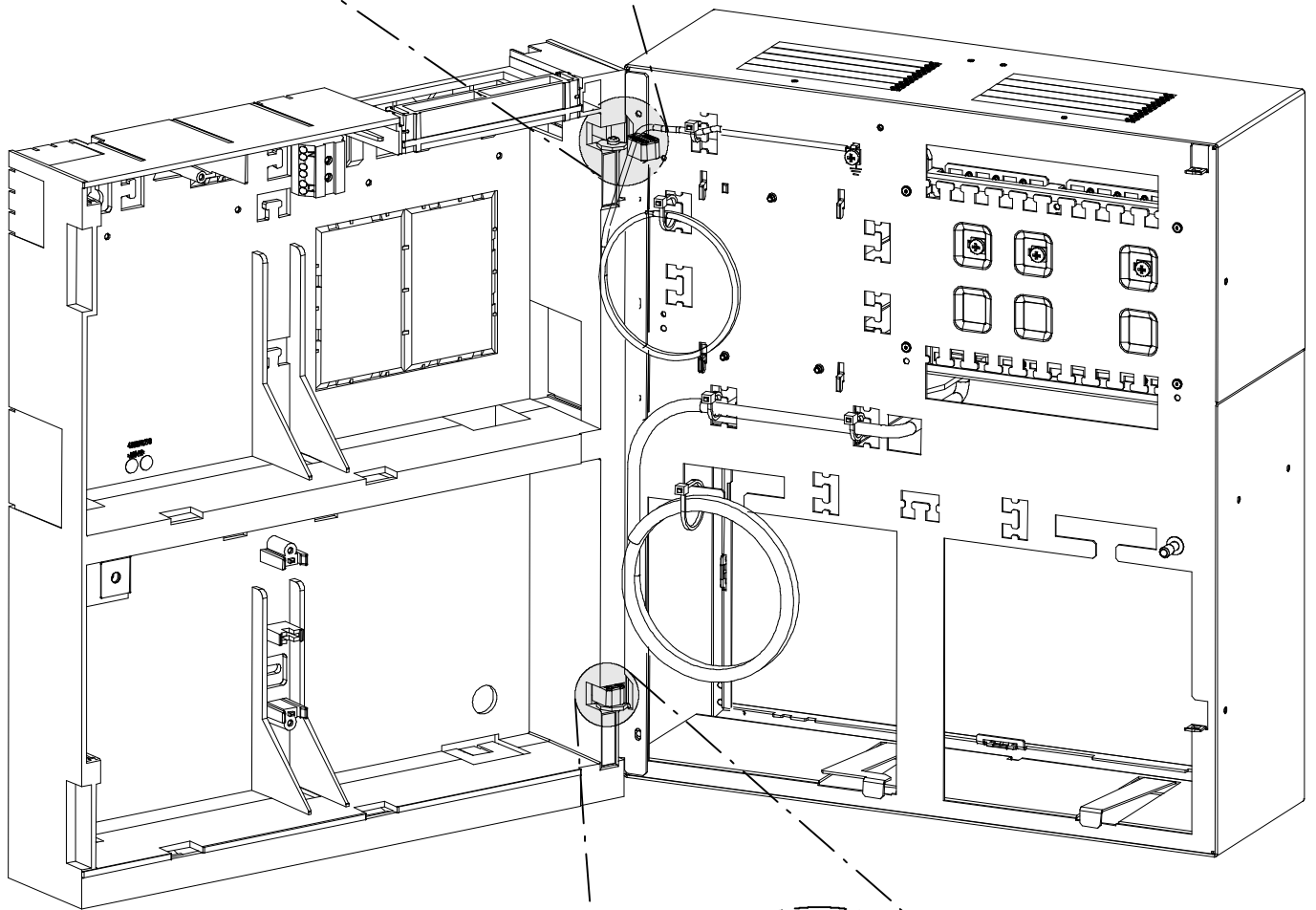
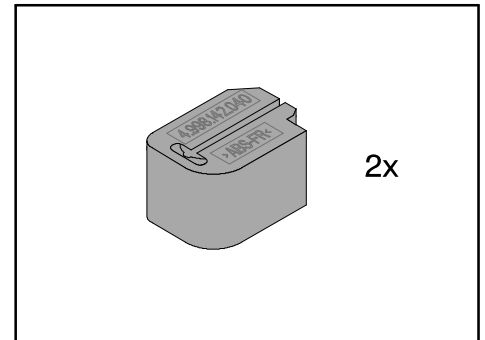
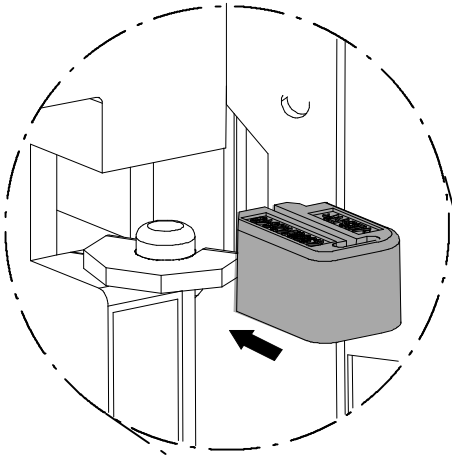



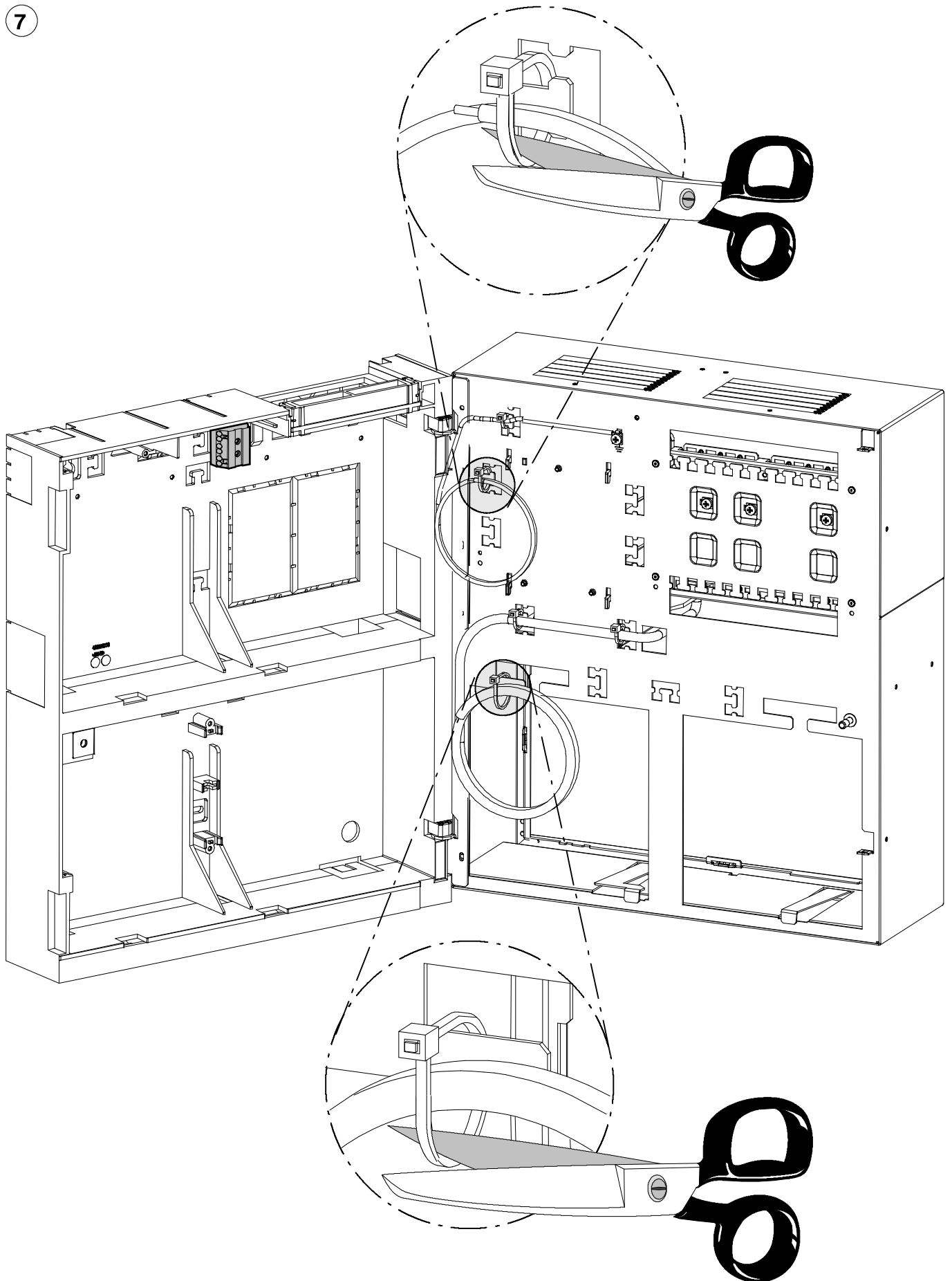





6



7



AL	 RREZIK	RREZIK GODITJE NGA TENSION! Prekja e pjesëve nën tension mund të jetë vdekjeprurëse. Shkëputni furnizimin me energji përpara se të lidhni pajisjet!
BG	 ОПАСНОСТ	ОПАСНОСТ ОТ ТОКОВ УДАР! Опасност за живота при докосване на тоководещи части. Преди довършителните работи да се изключи токът!
CZ	 NEBEZPEČÍ	NEBEZPEČÍ ÚRAZU ELEKTRICKÝM PROUDEM! Nebezpečí ohrožení života při dotyku vodivých dílů. Před připojováním zařízení odpojte od zdroje napětí!
D	 GEFAHR	GEFAHR EINES STROMSCHLAGS! Lebensgefahr bei Berührung stromführender Teile. Vor Installationsarbeiten die Stromzufuhr abschalten!
DK	 FARE	FARE FOR ELEKTRISK STØD! Livsfare ved berøring af strømførende dele. Slå strømmen fra, før der tilsluttes udstyr!
E	 PELIGRO	¡RIESGO DE UNA DESCARGAS ELÉCTRICA! Peligro de muerte al entrar en contacto con piezas que conduzcan corriente. Desconectar la alimentación antes de conectar el equipo!
EST	 OHT	ELEKTRILÖÖGI OHT! Elektrivoolu all olevate detailide puudutamine on eluohtlik. Katkestage toide enne seadme ühendamist!
F	 DANGER	RISQUE DE CHOC ÉLECTRIQUE ! Danger de mort en cas de contact avec les éléments sous tension. Débrancher l'alimentation avant de connecter l'équipement.
FIN	 VAARA	SÄHKÖISKUN VAARA! Sähköä johtavien osien koskettaminen voi aiheuttaa hengenvaaran. Katkaise virta ennen laitteiden liittämistä!
GB	 DANGER	RISK OF ELECTRIC SHOCK ! Danger of life with contact of live parts and wires. Disconnect power before connecting equipment!
GR	 KINΔYNOΣ	ΚΙΝΔΥΝΟΣ ΗΛΕΚΤΡΟΠΛΗΞΙΑΣ! Θανάσιμος κίνδυνος κατά την επαφή με τα ρευματοφόρα εξαρτήματα. Αποσυνδέστε την ισχύ πριν συνδέσετε το εξάρτημα!
H	 FIGYELEM	ÁRAMÜTÉSVESZÉLY! Az áramot vezető alkatrészek érintése életveszélyes. Valamely felszerelés csatlakoztatása előtt áramtalanítsa!
HR	 OPASNOST	OPASNOST OD STRUJNOG UDARA! Opasnost po život pri kontaktu s delovima pod naponom. Isključite napajanje prije priključivanja opreme!

I	 PERICOLO	PERICOLO DI SCOSSA ELETTRICA! Pericolo di morte attraverso il contatto con elementi conduttori di elettricità. Interrompere l'alimentazione prima di collegare le attrezzature!
LT	 PAVOJUS	ELEKTROS SMŪGIO PAVOJUS! Prisilietus prie dalių, kuriomis teka elektros srovė, gresia pavojus gyvybei. Prieš jungdami įrangą, išjunkite maitinimą iš tinklo!
LV	 BRIESMAS	STRĀVAS TIRECIENA DRAUDI! Pieskaršanās strāvu vadošām daļām apdraud dzīvību. Pirms pievienot iekārtas, atvienojiet strāvas padevi!
N	 FARE	FARE FOR ELEKTRISK STØT! Berøring av de strømførende delene kan medføre livsfare. Koble fra strømmen før du kobler til utstyret!
NL	 GEVAAR	GEVAAR VAN EEN STROOMSTOOT! Het aanraken van stroomgeleidende onderdelen is levensgevaarlijk. Sluit de voeding af voordat u apparatuur aansluit!
P	 PERIGO	PERIGO DE ELECTROCUSSÃO! Perigo de vida ao tocar nas peças condutoras de corrente. Desligue a alimentação antes de ligar o equipamento!
PL	 NIEBEZ-PIECZEŃSTWO	RYZIKO PORAŻENIA PRĄDEM ELEKTRYCZNYM! Śmiertelne niebezpieczeństwo przy dotknięciu części pod napięciem. Przed dołączeniem urządzeń należy odłączyć zasilanie!
RO	 PERICOL	PERICOL DE ELECTROCUTARE! Pericol de moarte la atingerea părților purtătoare de curent! Întrerupeți alimentarea înainte de a conecta echipamentul!
RUS	 ОПАСНОСТ	ОПАСНОСТЬ ПОРАЖЕНИЯ ЭЛЕКТРИЧЕСКИМ ТОКОМ! опасность для жизни при соприкосновении с токопроводящими деталями. Перед присоединением оборудования отсоединить питание!
S	 RISK	RISK FÖR STRÖMÖVERSLAG! Livsfara vid beröring av strömförande delar. Koppla bort strømmen innan du ansluter utrustning!
SCG	 OPASNOST	OPASNOST OD STRUJNOG UDARA! Opasnost po život u kontaktu sa delovima pod naponom. Isključite napajanje prije priključivanja opreme!
SLO	 NEVARNOST	NEVARNOST ELEKTRIČNEGA ŠOKA! Dotik delov pod električno napetostjo je smrtno nevaren. Pred priključitvijo opreme izklopite napajanje!
TR	 TEHLİKE	ELEKTRİK ÇARPMASI TEHLİKESİ! Elektrik ileten parçalar dokunulması durumunda hayati tehlike. Donanımı bağlamadan önce güç bağlantısını kesin!

8

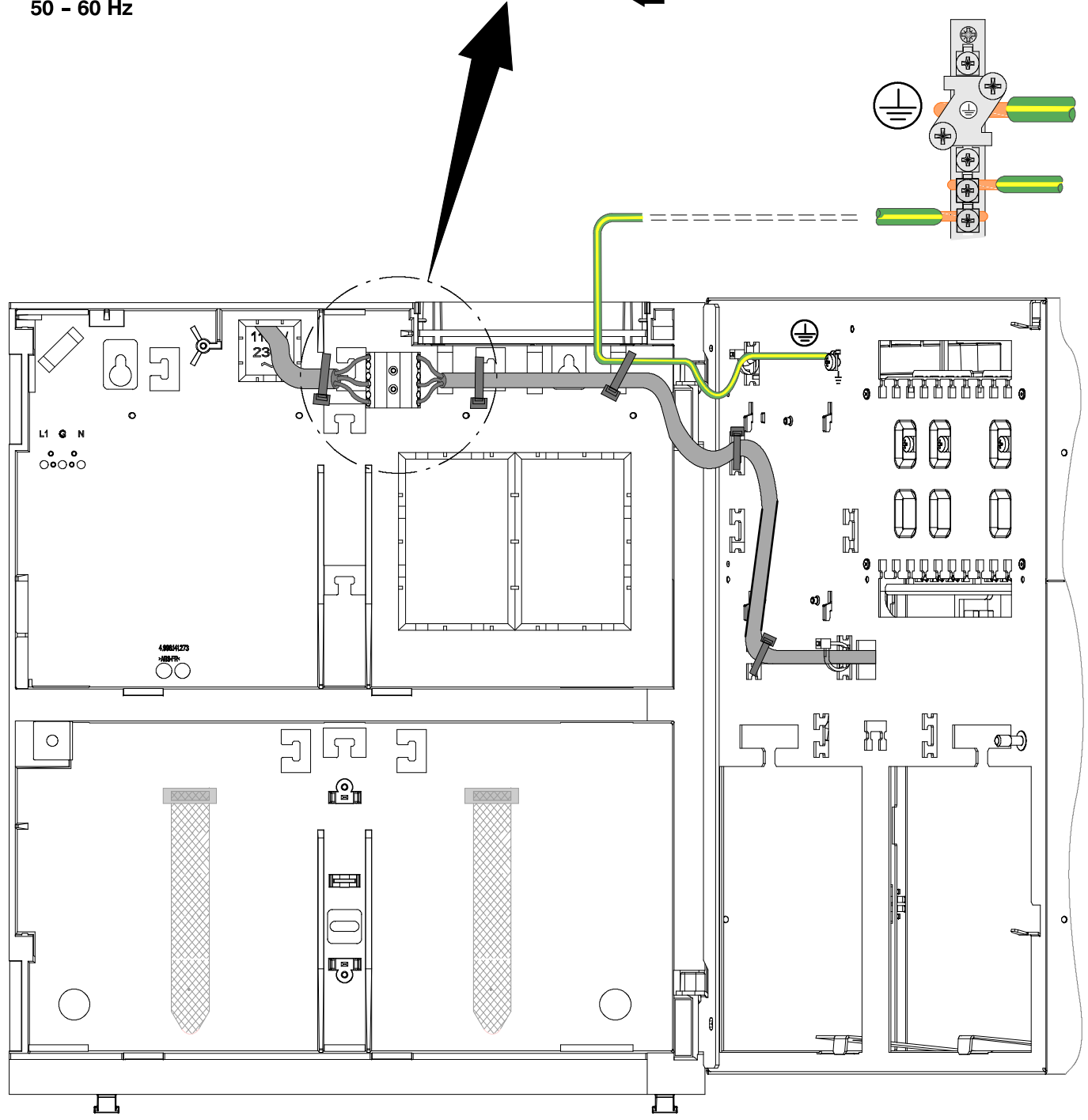
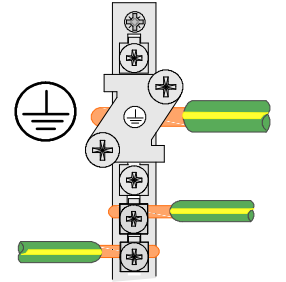
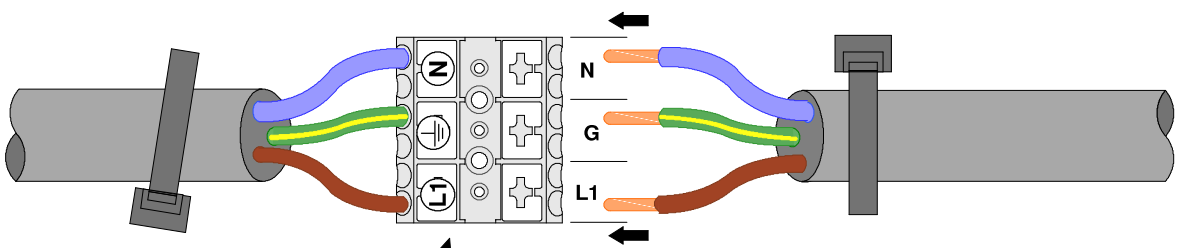

 100 - 240 V~
 50 - 60 Hz

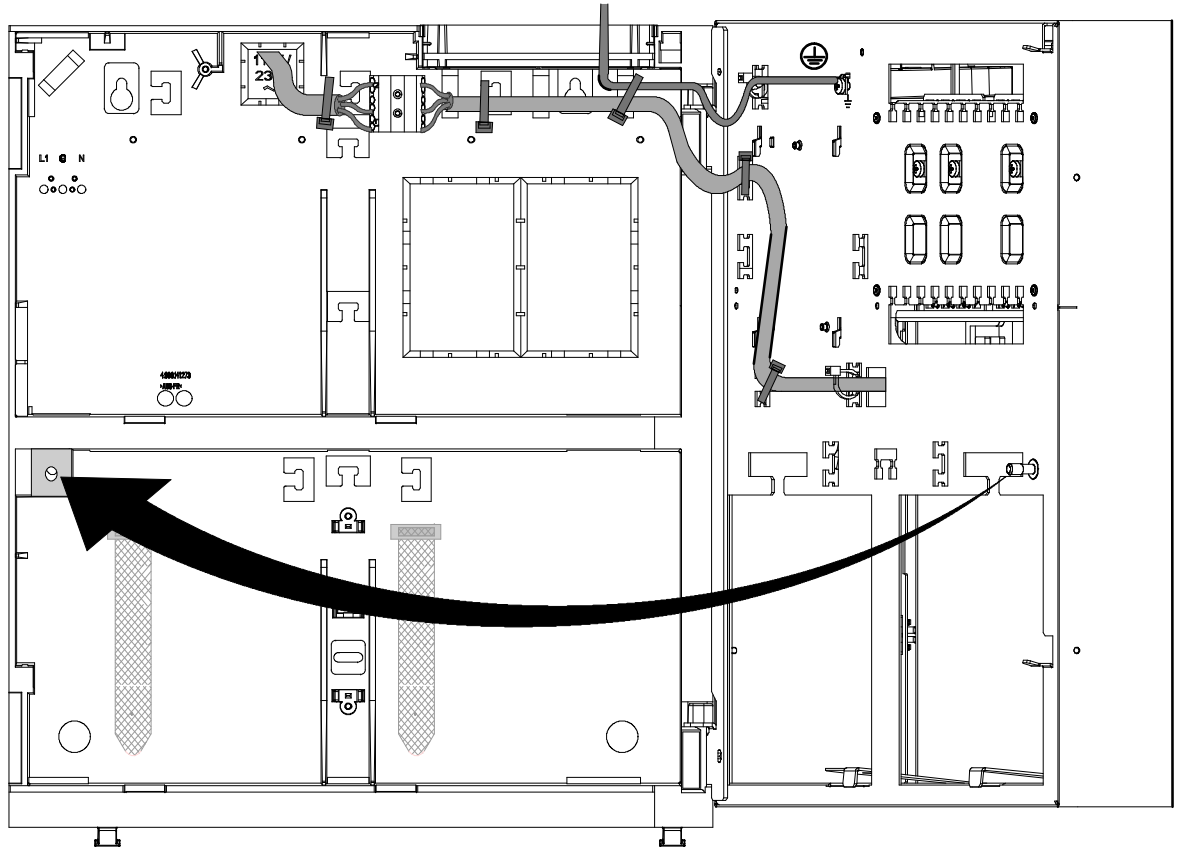

9

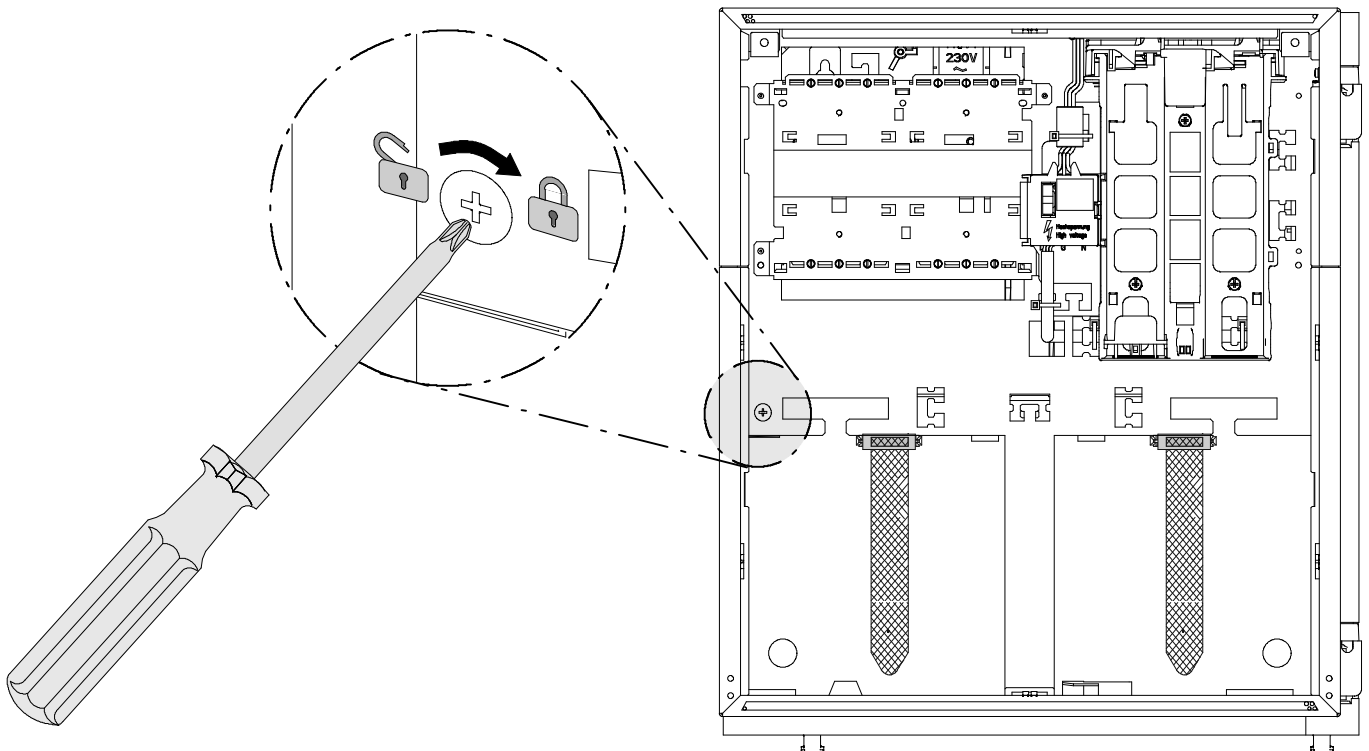

10



11

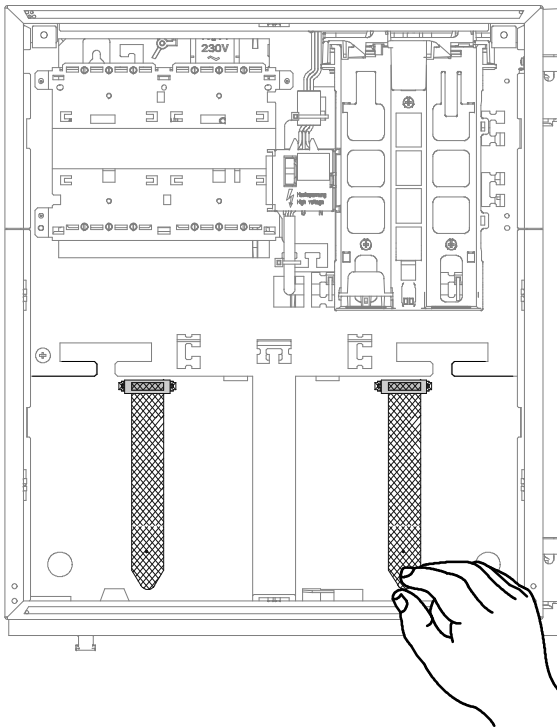

12

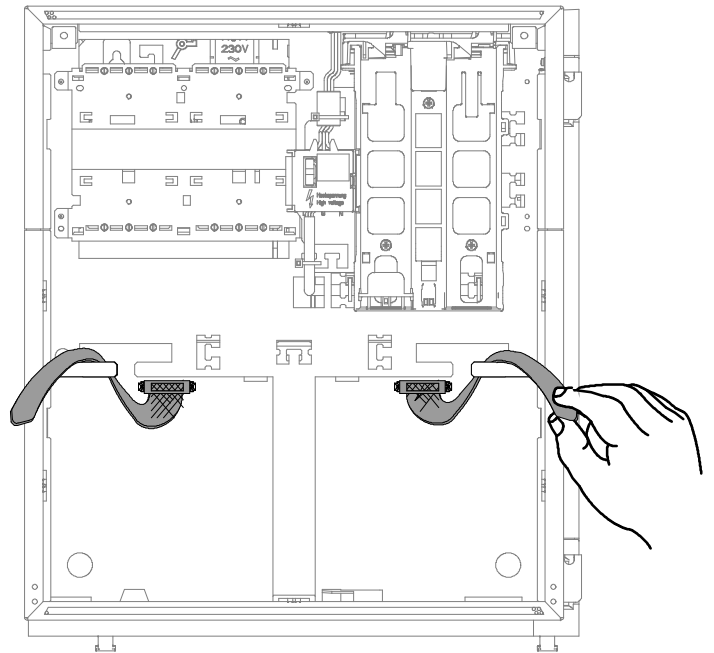

13

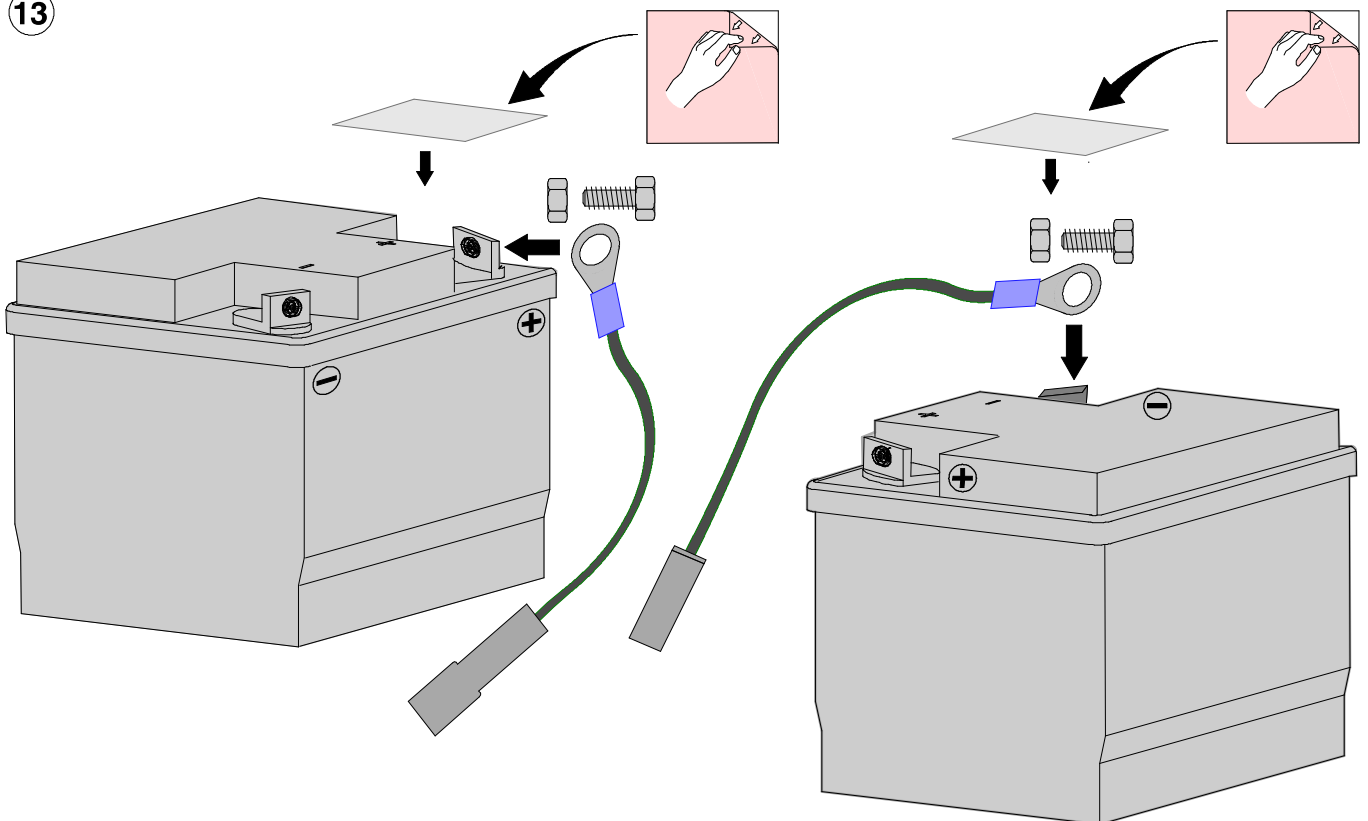

14

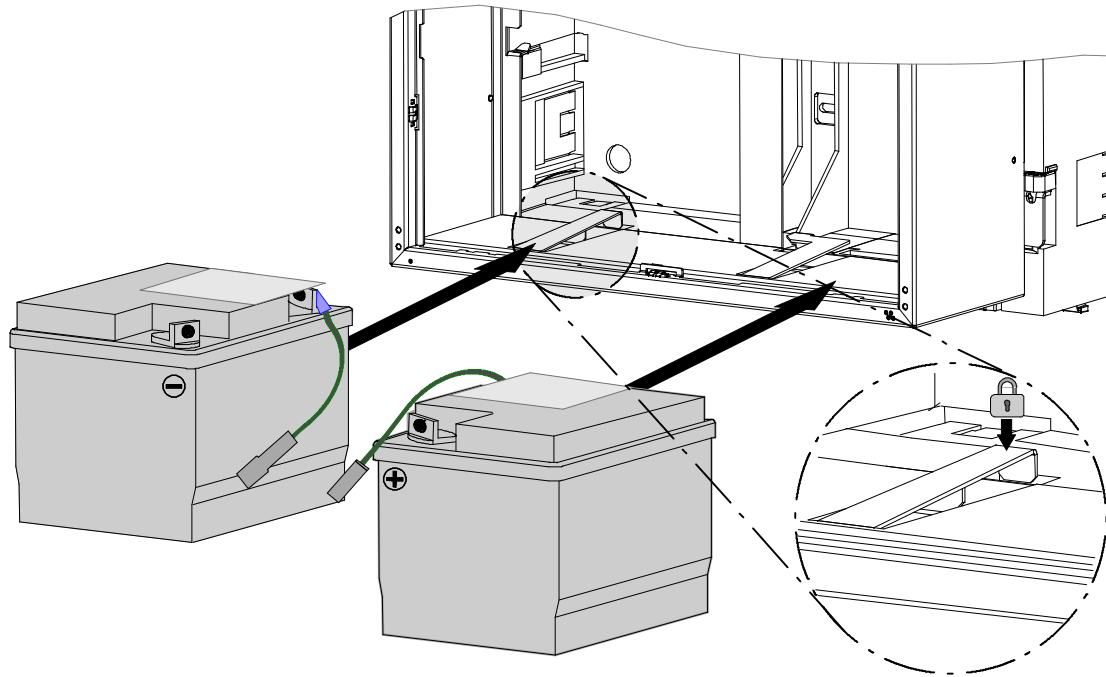

15

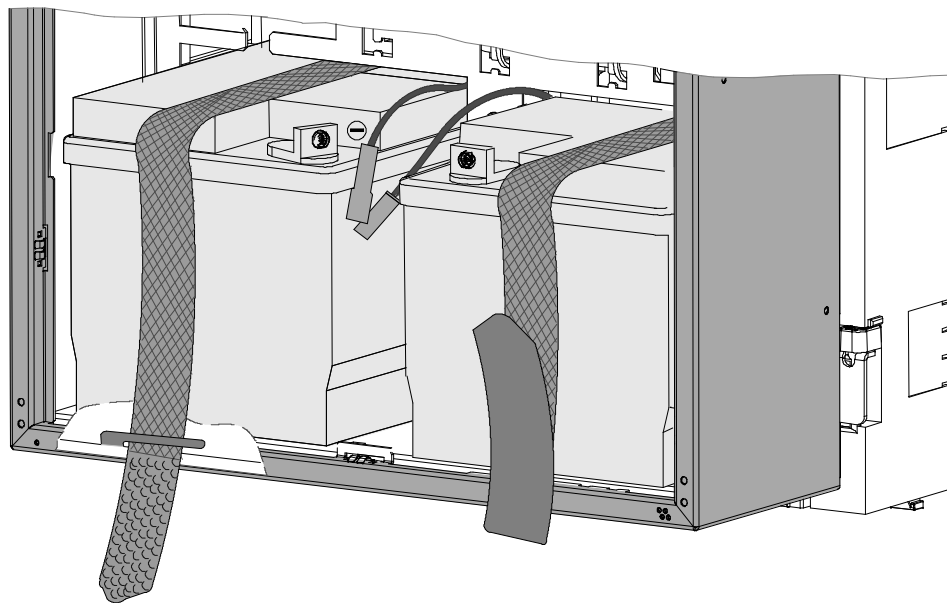

16

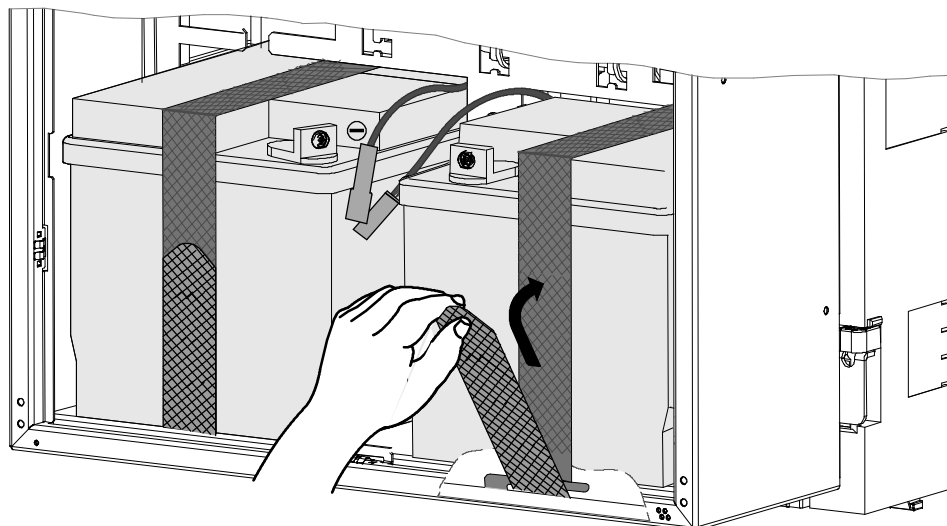

17

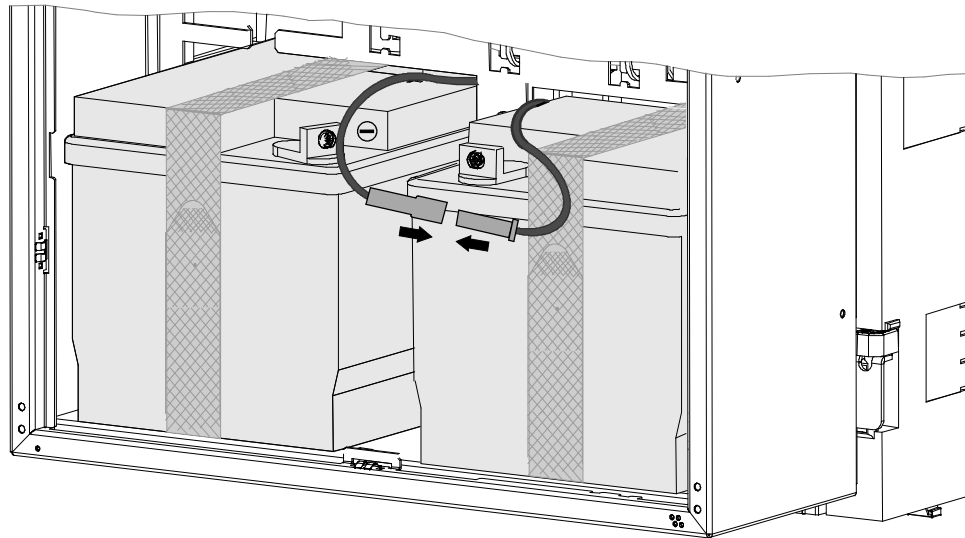

18

BCM 0000 A

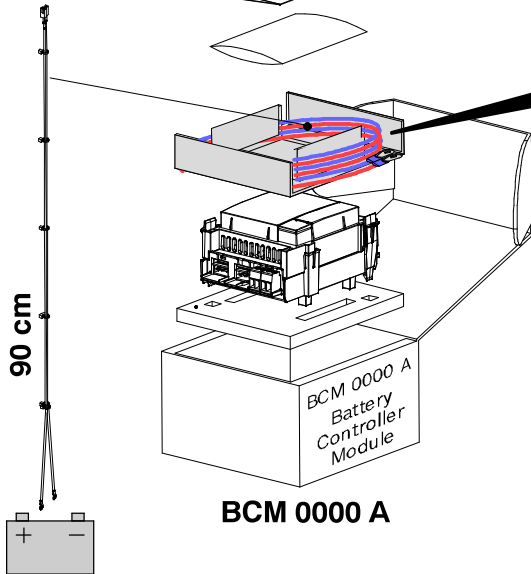

BCM 0000 A
Battery
Controller
Module

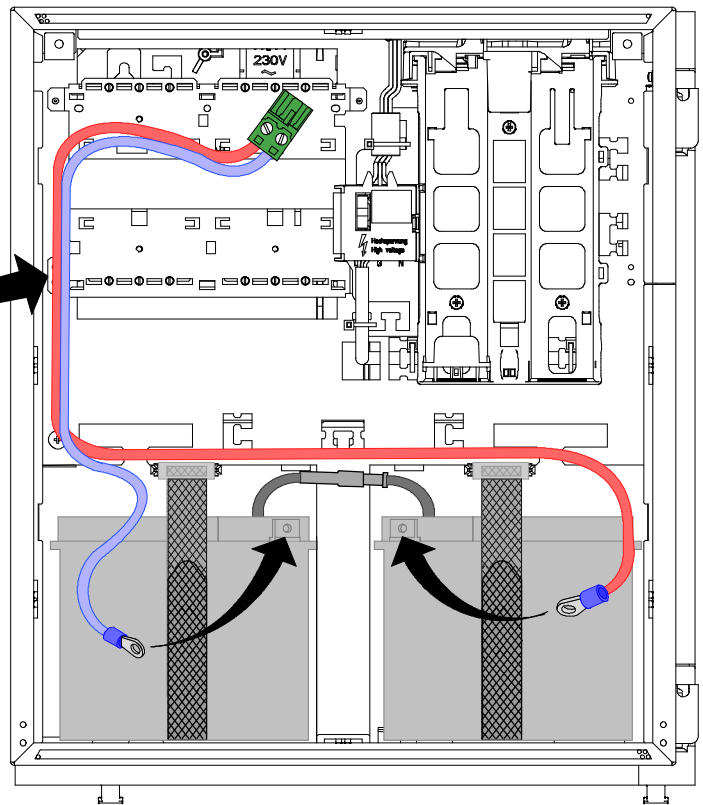

19

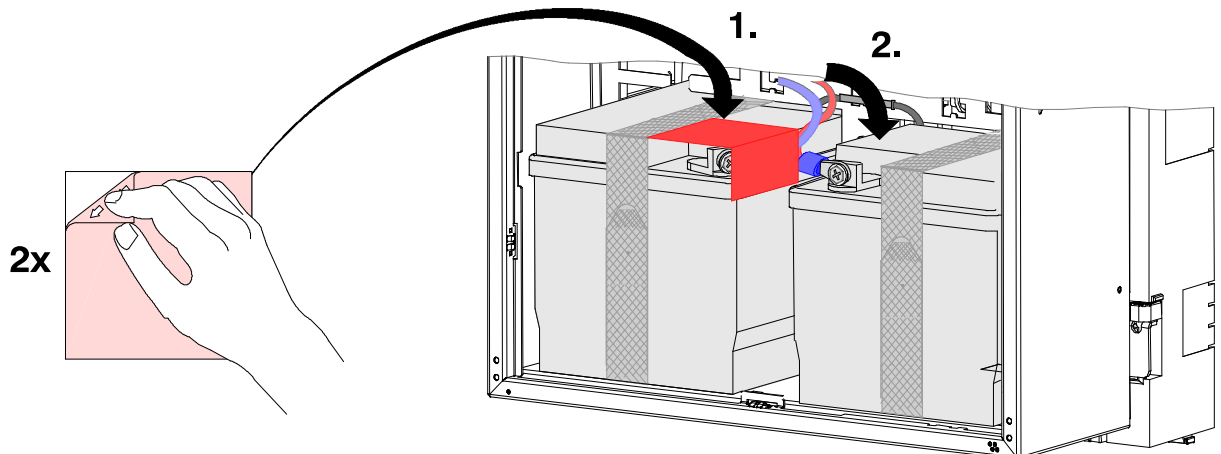

5

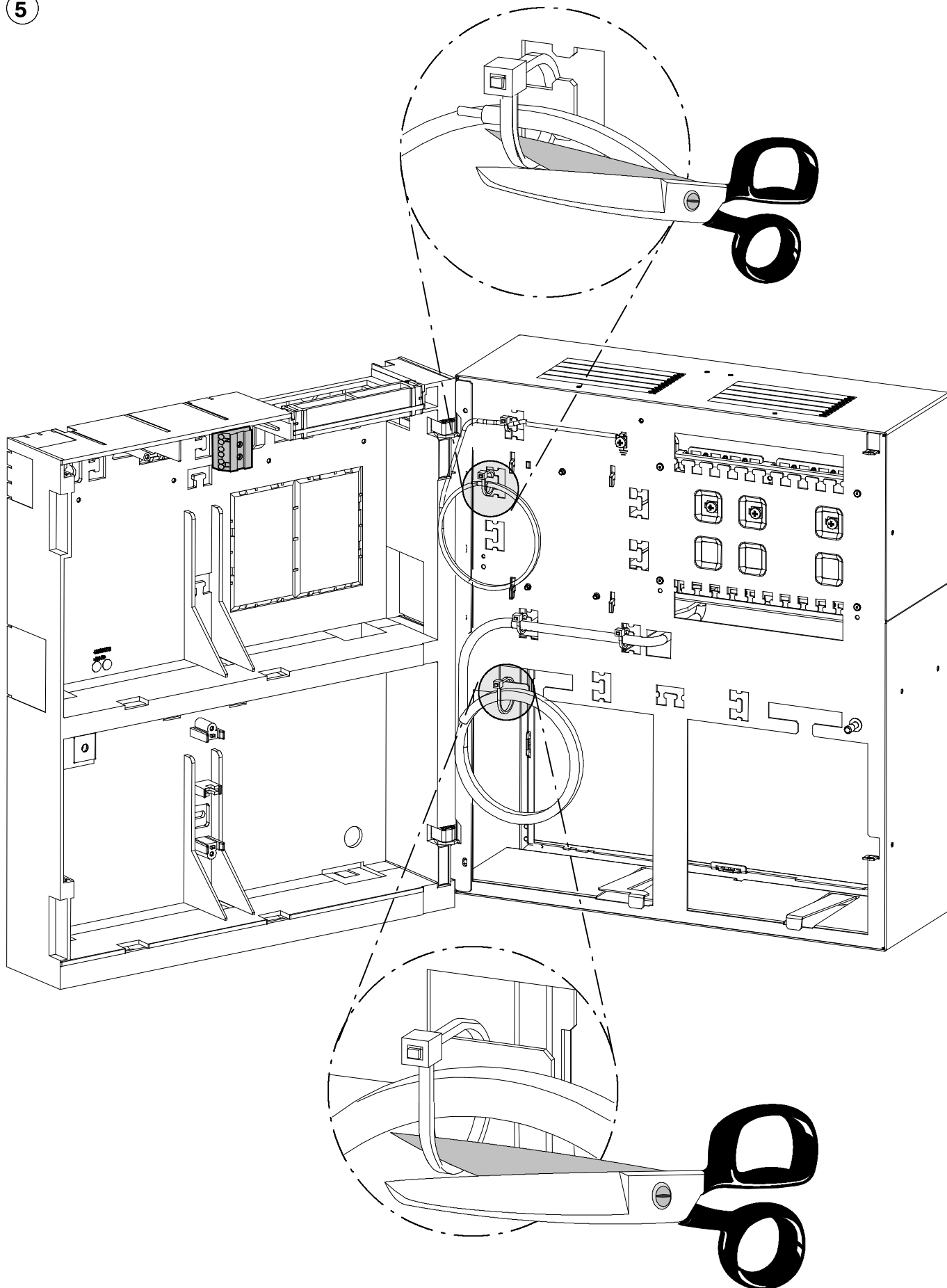



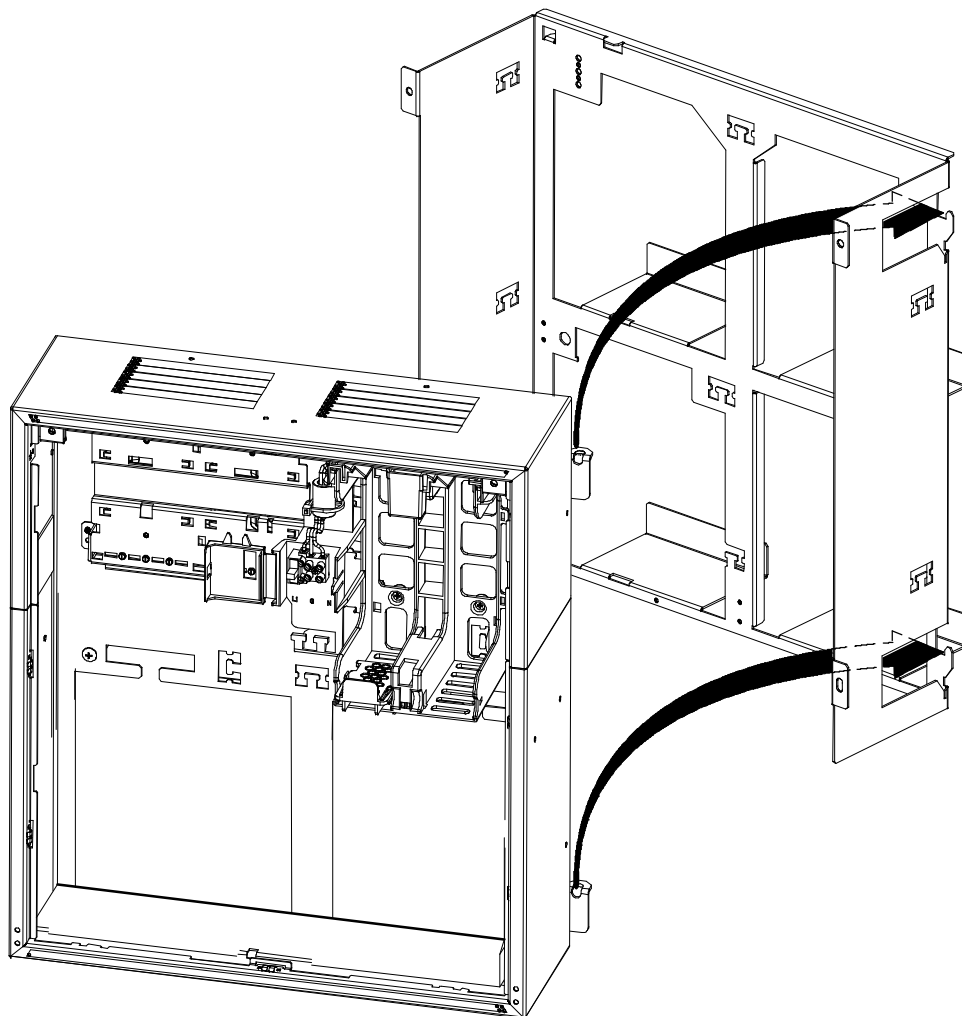



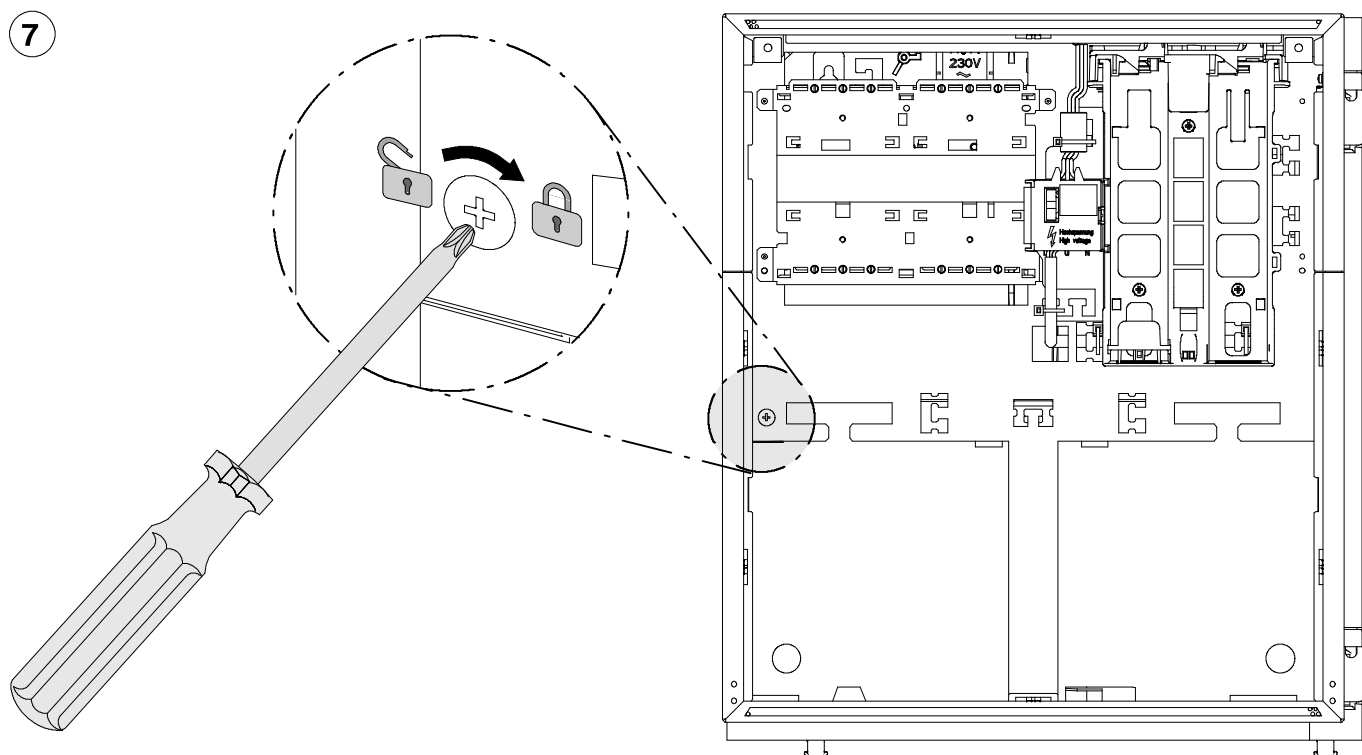





6



7



AL	 RREZIK	RREZIK GODITJE NGA TENSION! Prekja e pjesëve nën tension mund të jetë vdekjeprurëse. Shkëputni furnizimin me energji përpara se të lidhni pajisjet!
BG	 ОПАСНОСТ	ОПАСНОСТ ОТ ТОКОВ УДАР! Опасност за живота при докосване на тоководещи части. Преди довършителните работи да се изключи токът!
CZ	 NEBEZPEČÍ	NEBEZPEČÍ ÚRAZU ELEKTRICKÝM PROUDEM! Nebezpečí ohrožení života při dotyku vodivých dílů. Před připojováním zařízení odpojte od zdroje napětí!
D	 GEFAHR	GEFAHR EINES STROMSCHLAGS! Lebensgefahr bei Berührung stromführender Teile. Vor Installationsarbeiten die Stromzufuhr abschalten!
DK	 FARE	FARE FOR ELEKTRISK STØD! Livsfare ved berøring af strømførende dele. Slå strømmen fra, før der tilsluttes udstyr!
E	 PELIGRO	¡RIESGO DE UNA DESCARGAS ELÉCTRICA! Peligro de muerte al entrar en contacto con piezas que conduzcan corriente. Desconectar la alimentación antes de conectar el equipo!
EST	 OHT	ELEKTRILÖÖGI OHT! Elektrivoolu all olevate detailide puudutamine on eluohtlik. Katkestage toide enne seadme ühendamist!
F	 DANGER	RISQUE DE CHOC ÉLECTRIQUE ! Danger de mort en cas de contact avec les éléments sous tension. Débrancher l'alimentation avant de connecter l'équipement.
FIN	 VAARA	SÄHKÖISKUN VAARA! Sähköä johtavien osien koskettaminen voi aiheuttaa hengenvaaran. Katkaise virta ennen laitteiden liittämistä!
GB	 DANGER	RISK OF ELECTRIC SHOCK ! Danger of life with contact of live parts and wires. Disconnect power before connecting equipment!
GR	 KINΔYNOΣ	ΚΙΝΔΥΝΟΣ ΗΛΕΚΤΡΟΠΛΗΞΙΑΣ! Θανάσιμος κίνδυνος κατά την επαφή με τα ρευματοφόρα εξαρτήματα. Αποσυνδέστε την ισχύ πριν συνδέσετε το εξάρτημα!
H	 FIGYELEM	ÁRAMÜTÉSVESZÉLY! Az áramot vezető alkatrészek érintése életveszélyes. Valamely felszerelés csatlakoztatása előtt áramtalanítsa!
HR	 OPASNOST	OPASNOST OD STRUJNOG UDARA! Opasnost po život pri kontaktu s delovima pod naponom. Isključite napajanje prije priključivanja opreme!

I	 PERICOLO	PERICOLO DI SCOSSA ELETTRICA! Pericolo di morte attraverso il contatto con elementi conduttori di elettricità. Interrompere l'alimentazione prima di collegare le attrezzature!
LT	 PAVOJUS	ELEKTROS SMŪGIO PAVOJUS! Prisilietus prie dalių, kuriomis teka elektros srovė, gresia pavojus gyvybei. Prieš jungdami įrangą, išjunkite maitinimą iš tinklo!
LV	 BRIESMAS	STRĀVAS TIRECIENA DRAUDI! Pieskaršanās strāvu vadošām daļām apdraud dzīvību. Pirms pievienot iekārtas, atvienojiet strāvas padevi!
N	 FARE	FARE FOR ELEKTRISK STØT! Berøring av de strømførende delene kan medføre livsfare. Koble fra strømmen før du kobler til utstyret!
NL	 GEVAAR	GEVAAR VAN EEN STROOMSTOOT! Het aanraken van stroomgeleidende onderdelen is levensgevaarlijk. Sluit de voeding af voordat u apparatuur aansluit!
P	 PERIGO	PERIGO DE ELECTROCUSSÃO! Perigo de vida ao tocar nas peças condutoras de corrente. Desligue a alimentação antes de ligar o equipamento!
PL	 NIEBEZ-PIECZEŃSTWO	RYZIKO PORAŻENIA PRĄDEM ELEKTRYCZNYM! Śmiertelne niebezpieczeństwo przy dotknięciu części pod napięciem. Przed dołączeniem urządzeń należy odłączyć zasilanie!
RO	 PERICOL	PERICOL DE ELECTROCUTARE! Pericol de moarte la atingerea părților purtătoare de curent! Întrerupeți alimentarea înainte de a conecta echipamentul!
RUS	 ОПАСНОСТ	ОПАСНОСТЬ ПОРАЖЕНИЯ ЭЛЕКТРИЧЕСКИМ ТОКОМ! опасность для жизни при соприкосновении с токопроводящими деталями. Перед присоединением оборудования отсоединить питание!
S	 RISK	RISK FÖR STRÖMÖVERSLAG! Livsfara vid beröring av strömförande delar. Koppla bort strømmen innan du ansluter utrustning!
SCG	 OPASNOST	OPASNOST OD STRUJNOG UDARA! Opasnost po život u kontaktu sa delovima pod naponom. Isključite napajanje prije priključivanja opreme!
SLO	 NEVARNOST	NEVARNOST ELEKTRIČNEGA ŠOKA! Dotik delov pod električno napetostjo je smrtno nevaren. Pred priključitvijo opreme izklopite napajanje!
TR	 TEHLİKE	ELEKTRİK ÇARPMASI TEHLİKESİ! Elektrik ileten parçalar dokunulması durumunda hayati tehlike. Donanımı bağlamadan önce güç bağlantısını kesin!

8

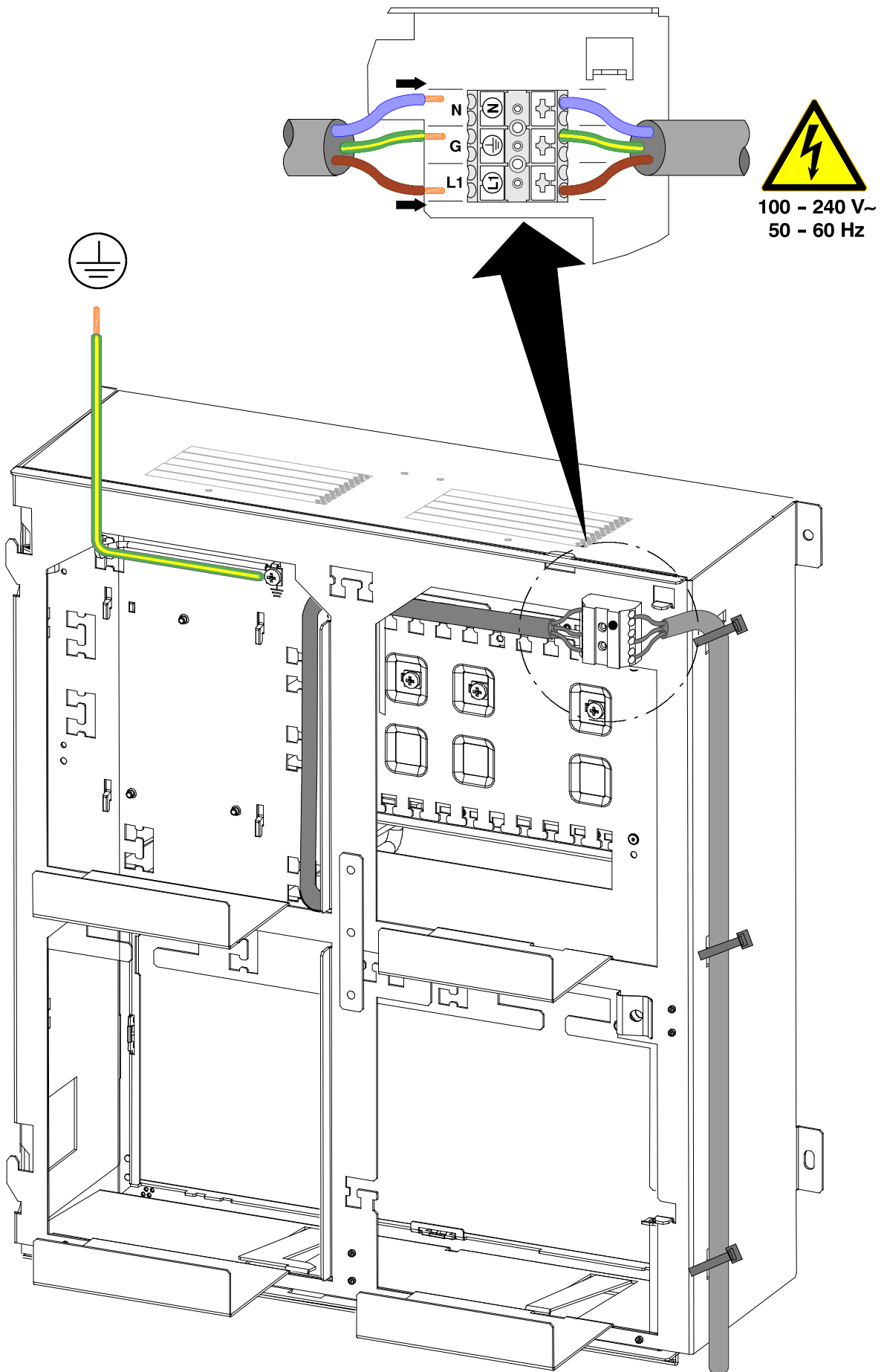

12

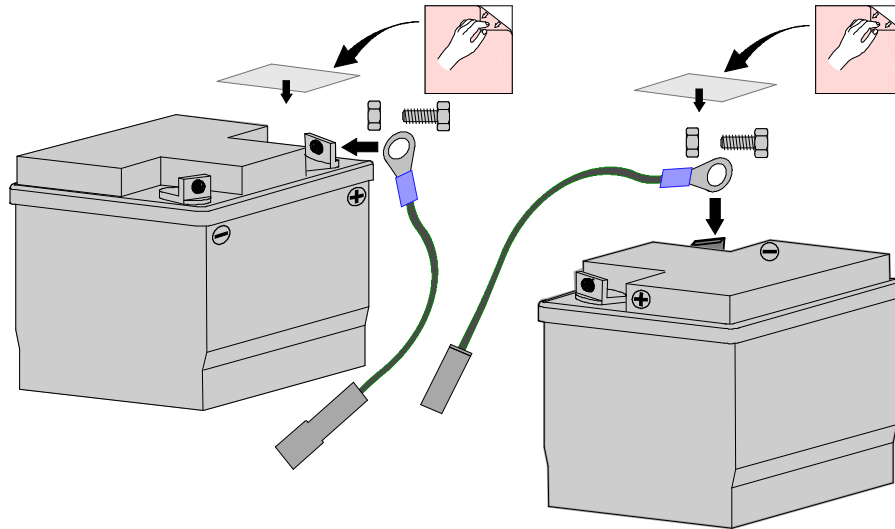

13

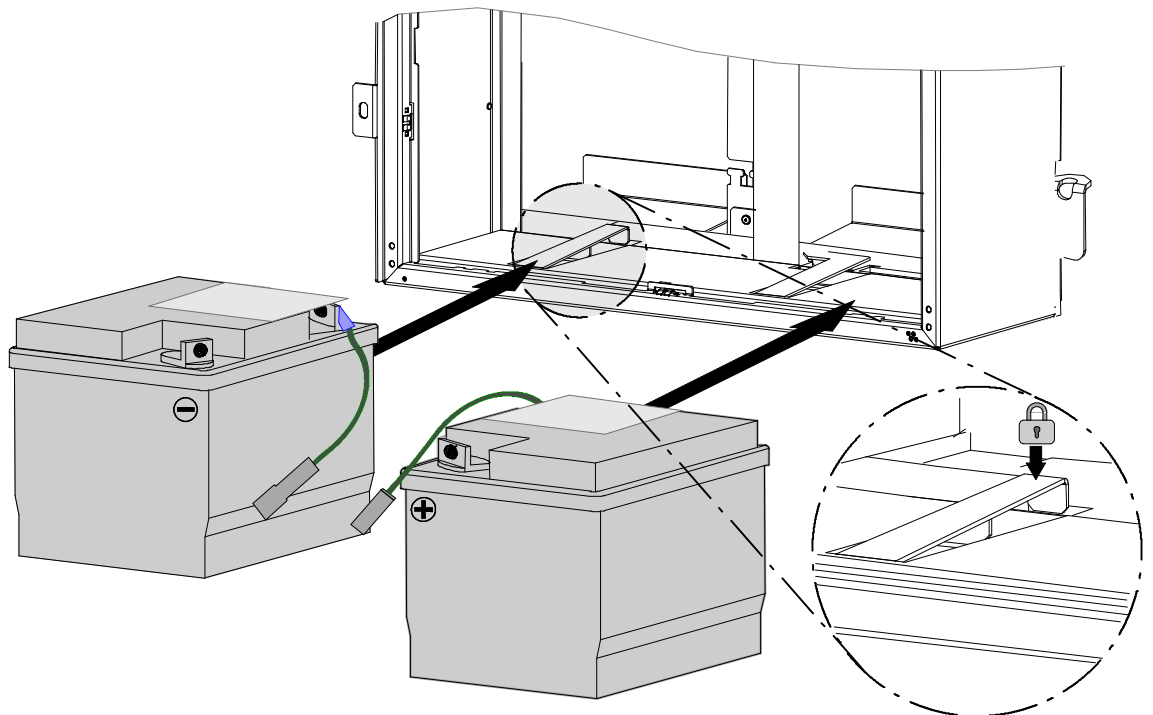

14

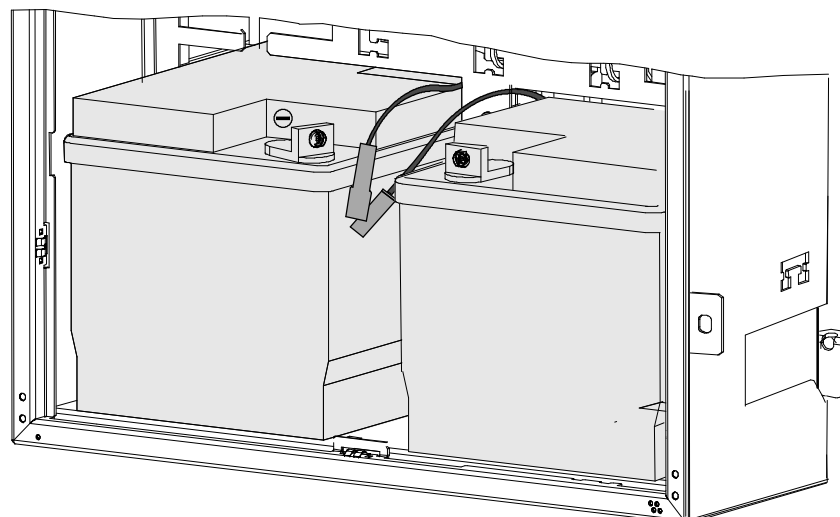

15

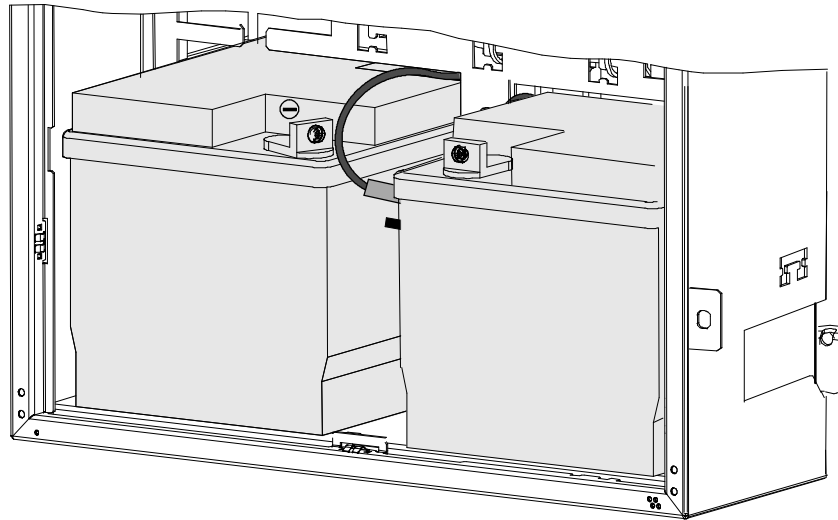

16

BCM 0000 A

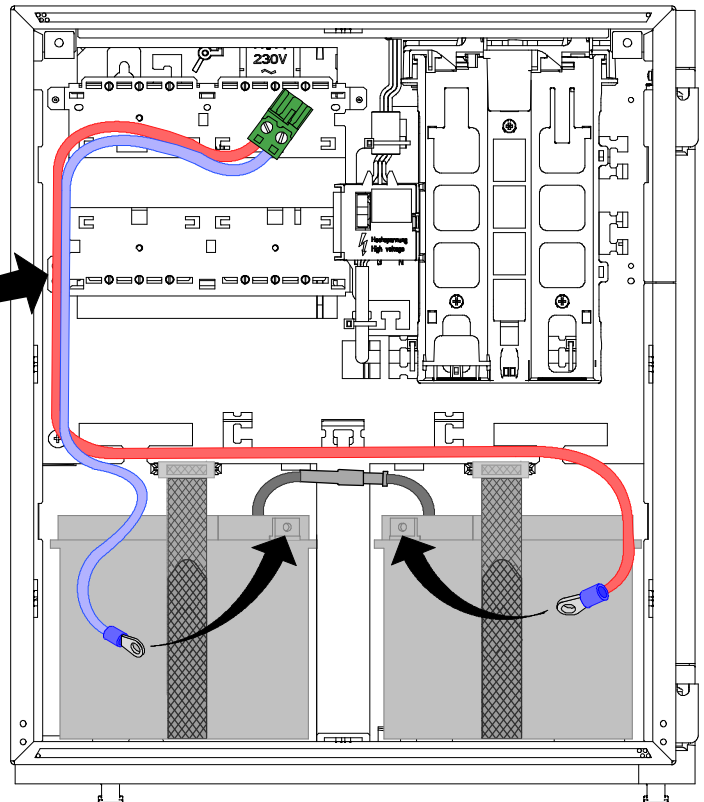
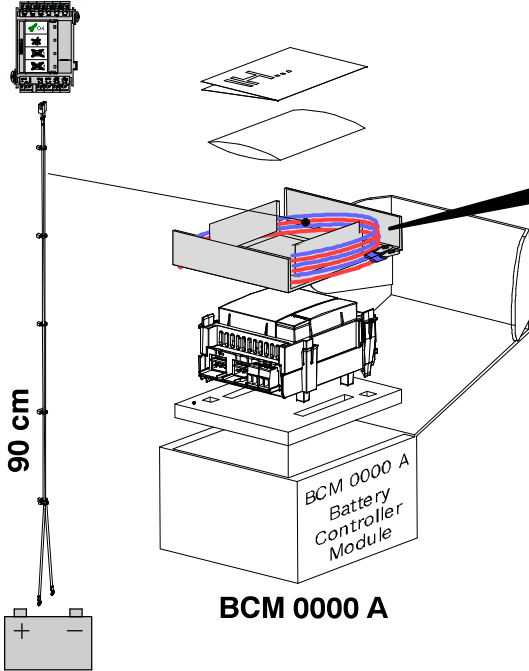

17

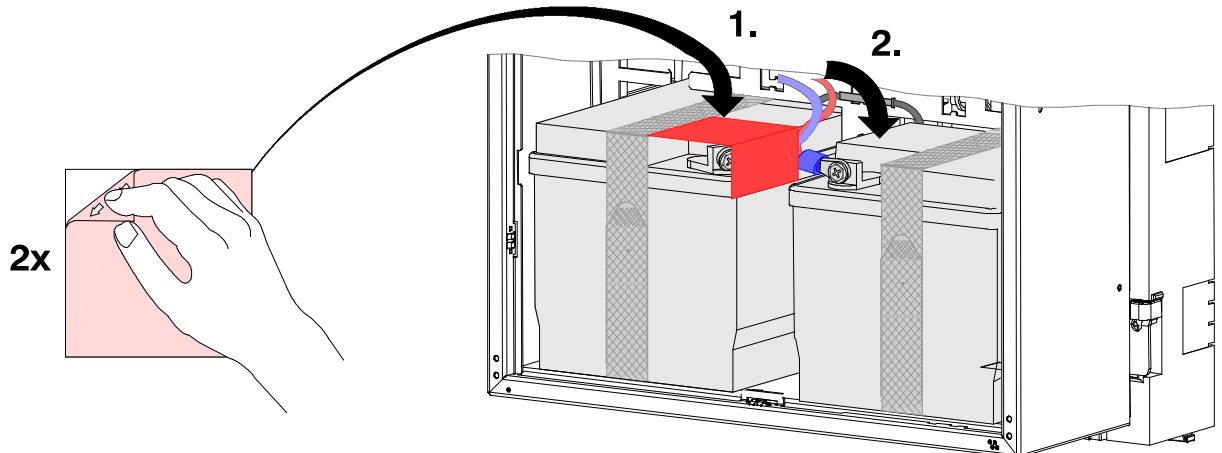



Bosch Sicherheitssysteme GmbH
Robert-Koch-Straße 100
D-85521 Ottobrunn

Info-Service
www.bosch-sicherheitssysteme.de
info.service@de.bosch.com